

Features

Series:	T
Type:	20
Code:	07.225.041.11
Description:	T200610ENC12C12
Customer's code:	-
Colour:	Black

Last drawing

Index:	-	Date:	-
--------	---	-------	---

Application

-

Driveline data

X	1 3/8" Z6 DIN 9611
Y	1 3/8" Z6 DIN 9611
E	485-19.09"
I	500-19.69"
P	420-16.54"

Overlap

	Steel tubes	Guard
Max.	465-18.31"	400-15.75"
Min.	151-5.94"	86-3.39"

Greasing point

1)	-
2)	-

The dimensioning is cross to cross

Cross and tubes

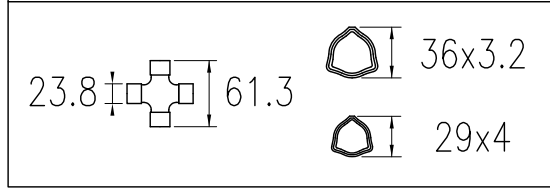

End fittings	Max. torque
Tractor Cod: C12	-
Implement Cod: C12	-

Notes:
 CERTIFIED

Warning !
 Sections of driveline marked are not shielded and must be shielded by an interactive guarding system.
 COMER spa declines responsibility if proper guards are not provided or maintained.

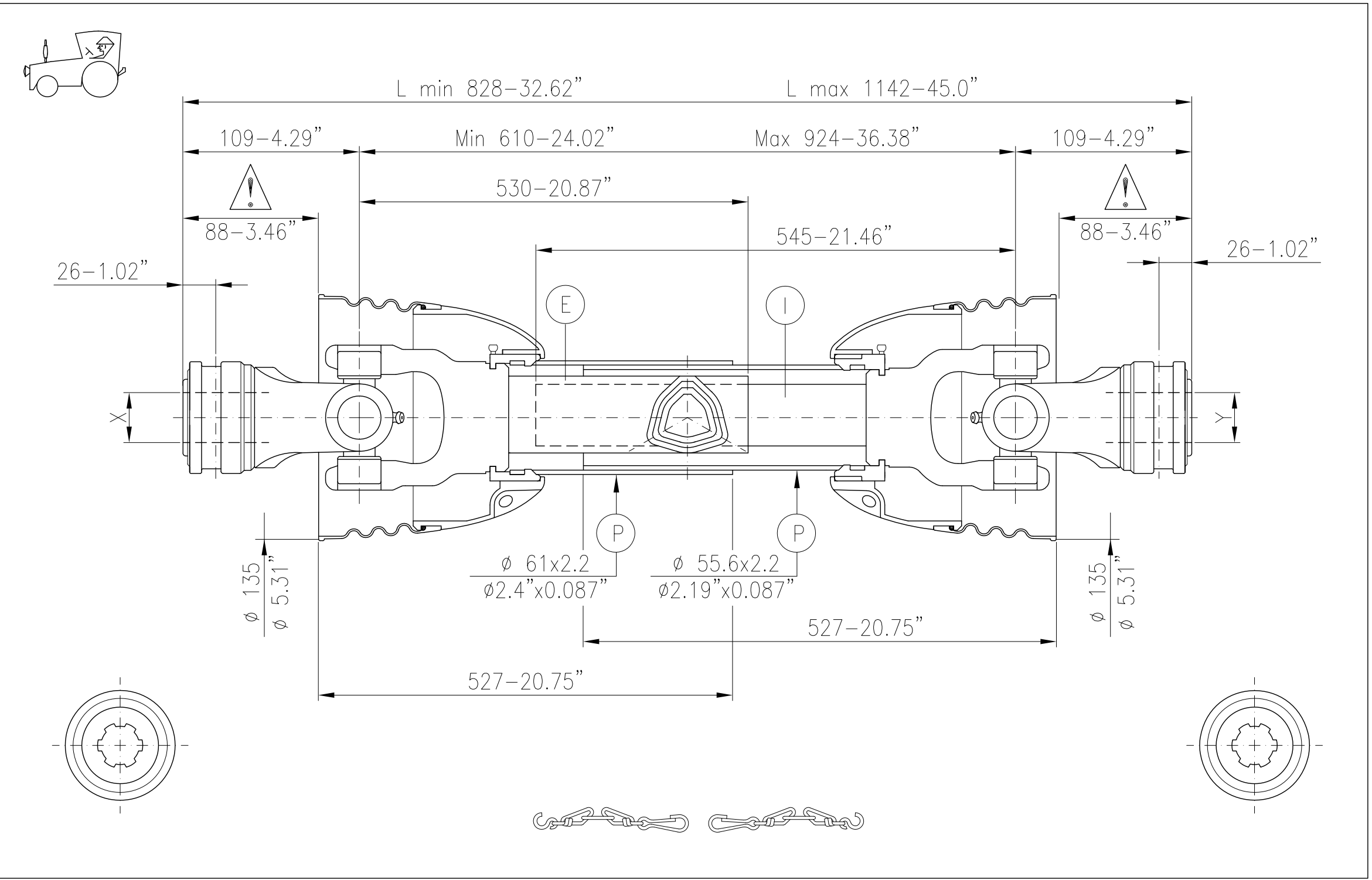

KW	CV	Data 540 r.p.m.		Data 1000 r.p.m.		1100 min. ⁻¹ r.p.m. max.	Data for only critical velocity		Customer: --
		Nm.	in.lb.	Nm.	in.lb.		540 r.p.m.	1000 r.p.m.	
15	21	270	2400	23	1950		Max.	-	Date: 28-08-20
							L max.	-	
Continuous operation data and conditions, working angle 5°, average life 1000 hours							Checked:	Signed by: A.Sa.	